

INDUSTRIAL PARK KHMELNYTSKYI

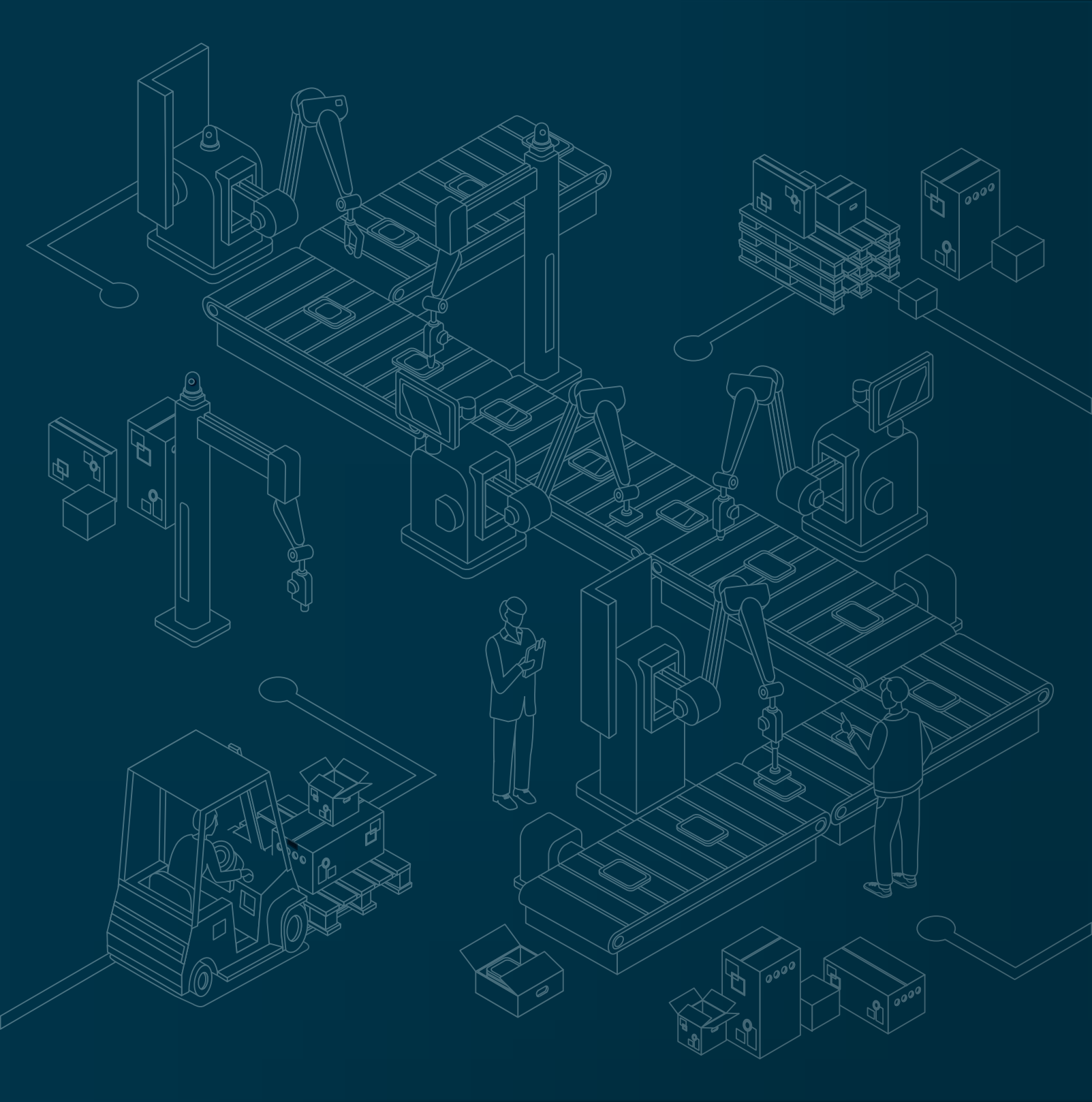



CONTENTS

- CITY LOCATION 2
- KEY FACTS 3
- ECONOMIC DATA 4
- TRADITIONAL BRANCHES OF ECONOMY 6
- LABOUR MARKET 8
- FOREIGN ECONOMIC ACTIVITY 12
- EDUCATION 14
- INDUSTRIAL PARK KHMELNYTSKYI 16
- INDUSTRIAL PARK LOCATION 18
- INDUSTRIAL PARK PLANNING DOCUMENTS 22
- ADVANTAGES FOR PARTICIPANTS OF INDUSTRIAL PARK (NATIONAL LEVEL) 23
- PRIVILEGES TO BE ADOPTED IN THE NEAR FUTURE 24
- ADVANTAGES FOR PARTICIPANTS OF INDUSTRIAL PARK PROVIDED BY THE CITY 26
- ADVANTAGES FOR PARTICIPANTS OF INDUSTRIAL PARK PROVIDED BY THE MANAGING COMPANY 27
- THE SCHEME OF THE INDUSTRIAL PARK 28
- INFRASTRUCTURE OF THE INDUSTRIAL PARK 30
- PRIORITY AREAS OF PRODUCTION 31
- KHMELNYTSKYI INDUSTRIAL PARK ORGANIZATIONAL MODEL 32
- THE PERIOD FOR WHICH THE INDUSTRIAL PARK IS CREATED 34
- EXPECTED RESULTS 35
- CONTACTS 36

CITY LOCATION



4h

Kyiv, the capital and the largest city in Ukraine, is only 4 hours away from Khmelnytskyi.



24h

Warsaw, Moscow, Istanbul, Helsinki, Prague, Berlin, Budapest and Bucharest are within 24 hours via road transport.



4h

Krakovets-Korchova, is a land border crossing between Ukraine and Poland. Start of A4 motorway.

KEY FACTS

Area	93.05 km ²
Time zone	UTC +2
Climate	Temperate continental
Accessibility	By train – from Poland, Slovakia, Romania, Bulgaria. By bus – from more than 100 European cities.
Population (2020)	274,602
National currency	Hryvnya (UAH / ₴)
Number of enterprises (2020)	30,028
The largest sectors of the economy based on the number of enterprises	Trade and Services Engineering Industry Production of chemicals and chemical products Production of building materials Wood products, paper production and printing activities Textile production, clothing, leather goods and other materials Food processing industry
Capital investments for the oblast (2020)	9,2 Billion ₴/ € 265.4 mln
Information about Khmelnytskyi	khm.gov.ua invest.khm.gov.ua



THE SAFEST CITY IN UKRAINE



THE LARGEST TRADING CENTER IN WESTERN UKRAINE



CITY IS DRIVEN BY SMALL AND MEDIUM ENTERPRISES



A JUNCTION OF MAJOR TRANSPORT ROUTES



EFFICIENT DISTANCES

it takes 20 minutes to get from one side of the city to another



THE MOST AFFORDABLE HOUSING MARKET

among regional centers of Western and Central Ukraine

ECONOMIC DATA

Key Economic Data	2020
Population (2020)	274,602
Volume of industrial products sales	€13,9 billion / €451.4 mln
Retail turnover	€9.2 billion / €295.6 mln
GDP in Khmelnytskyi region (oblast) in 2019	€48859 mln/ €1.6 mln
Consumer price index (for the oblast)	100.4
Number of the registered business entities	30.028
Average gross monthly salary	€9.599/€281
Average gross monthly salary as measured versus the national average (Ukraine=100)	83% (statistic data)

>274,000
inhabitants

14th
largest regional center in terms of population size

>30,000
registered businesses

12,676
legal entities
22,691
individual-entrepreneurs

Population

in comparison with other European cities, thousand people

Strasbourg	284,6	
Wiesbaden	278,4	
Khmelnytskyi	274,6	
Aachen	249	
Chemnitz	246,3	
Kosice	240,7	
Magdeburg	237,6	
Lille	232,8	
Erfurt	214	
Rzeszow	184	
Potsdam	178,1	
Salzburg	152,4	

Khmelnytskyi Age Distribution

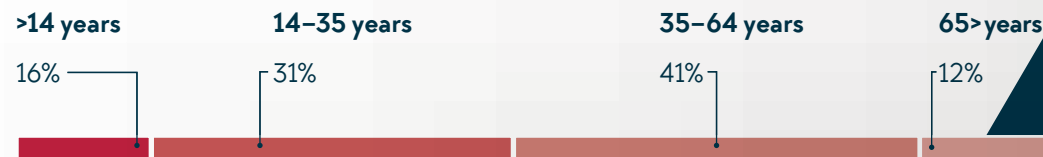

Medium-sized enterprises

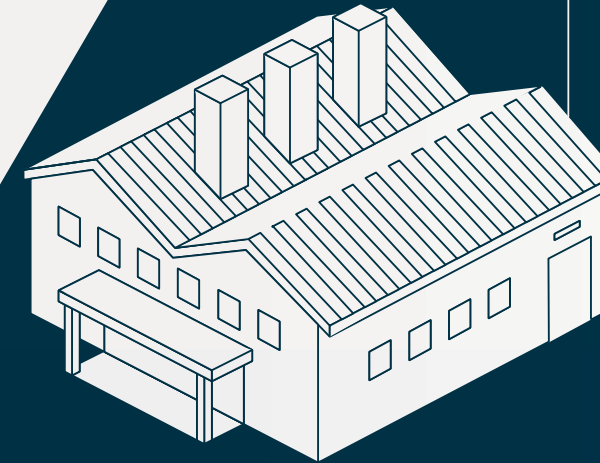

54.4%

of the total numbers of employees

26 518

total numbers of employees

Small enterprises

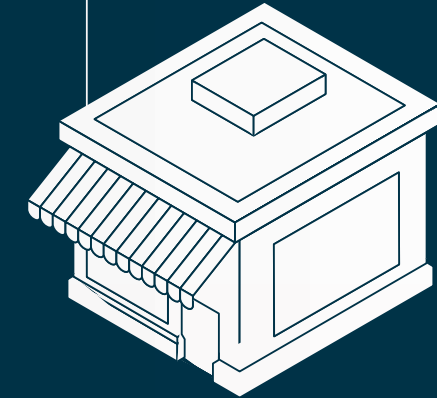

36.2%

of the total numbers of employees

17 876

total numbers of employees

Enterprises revenue before taxes for 2019 amounted to €1101.1 billion (35.8 mln EUR) profit.

The city has a significant weight in the economy of the region in a number of indicators.

The share of the city in the economy of the region (as for June 2020)	%
Industrial products sales	29.5
Volume of capital investments	44.2
Exports of goods	20.9
Import of goods	58.9
Retail sales	56.9

TRADITIONAL BRANCHES OF ECONOMY

In the second half of the 20th century, Khmelnytskyi became home to a number of significant industrial manufacturers. This included Tractordetal, a producer of transformer substations; Kation, a radio engineering and thermoplastics firm and SE Novator, one of the country's largest manufacturers of capacitors. Other industrial, construction, food and light industry companies also started during this time.

The emergence of these firms transformed the City of Khmelnytskyi into a large industrial center for Ukraine. A major engineering university and technical institute — the Khmelnytskyi National University — was founded to support their need for a capable workforce.

In 1987, Khmelnytskyi's famous clothing market opened. The operation grew into a large market complex is now a well established wholesale and retail clothing market, spanning 30 hectares. Today, the Khmelnytskyi Clothing Bazaar is considered as one of the largest in Ukraine and Eastern Europe and has close economic relations with foreign partners from Poland, Turkey, China, India and Vietnam. As results of the market, trade and services, industry, construction, and logistics became the drivers of the Khmelnytskyi's economy. The City is actively developing the sphere of information technology.

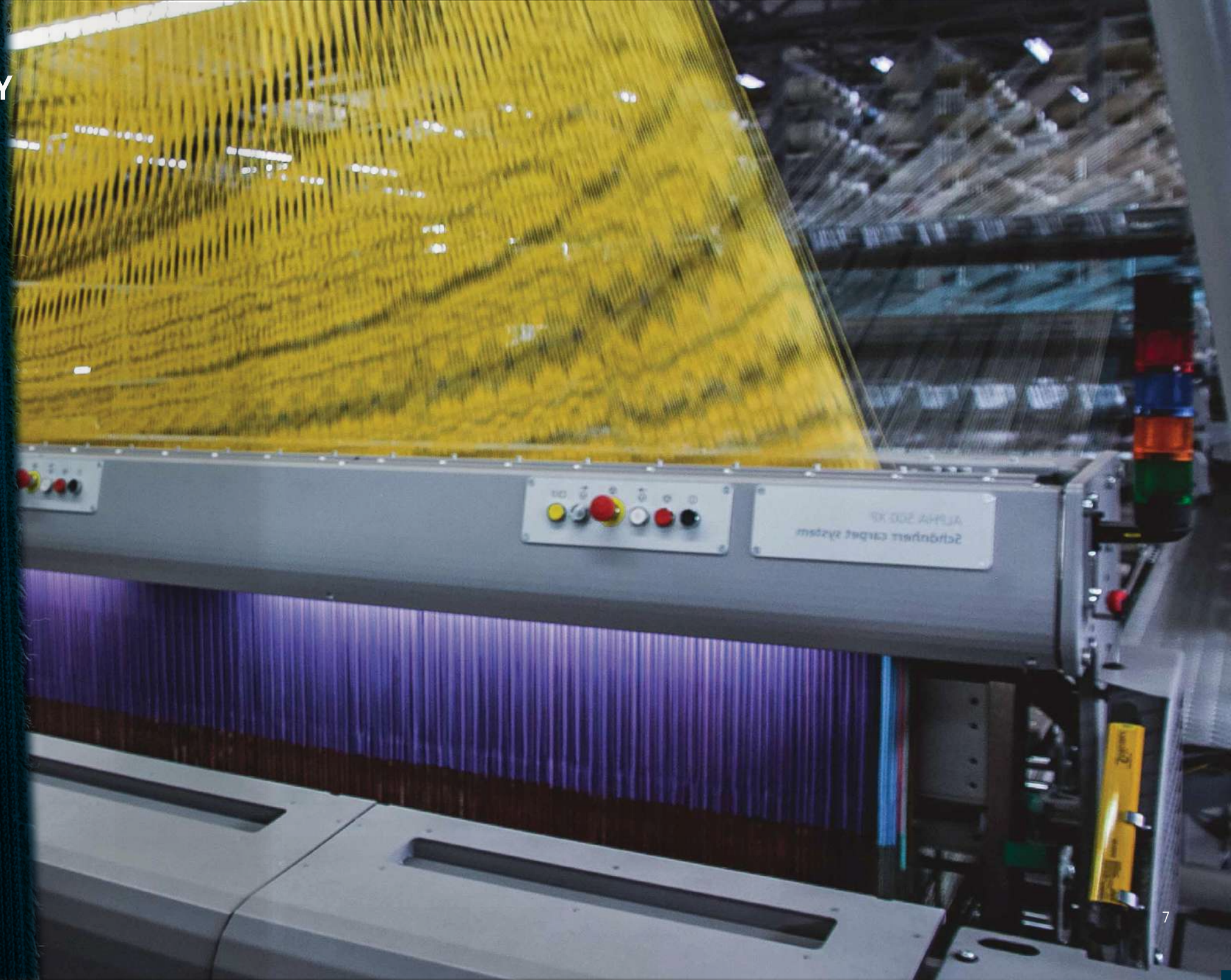

LABOUR MARKET

One of the city's greatest assets is the employment potential. It is represented in trade and services, transport, logistics and storage, engineering industry, garment industry and IT.

The highest employment growth is currently expected in food services, construction, transport, industry and logistics segments.

The average monthly salary of full-time employees in 2020 amounted to €9599 (281 €) (in Ukraine ₴11591 (376.5 €)).

An additional important advantage is the possibility to use the assistance of the labour market institutions. They match employers with job seekers. The website of *Khmelnytskyi* Regional Employment Center (khm.dcz.gov.ua) and a special service for job and personnel search, which is called *HeadHunter.UA*, (khmelnitsky.hh.ua) contain useful information about vacancies, employees and featured jobs.

What may encourage the opening of a business in *Khmelnytskyi* are relatively low labour and employment costs.

official number
of unemployed

1676

DYNAMICS OF AVERAGE MONTHLY SALARY OF FULL-TIME EMPLOYEES, %

(statistic data).

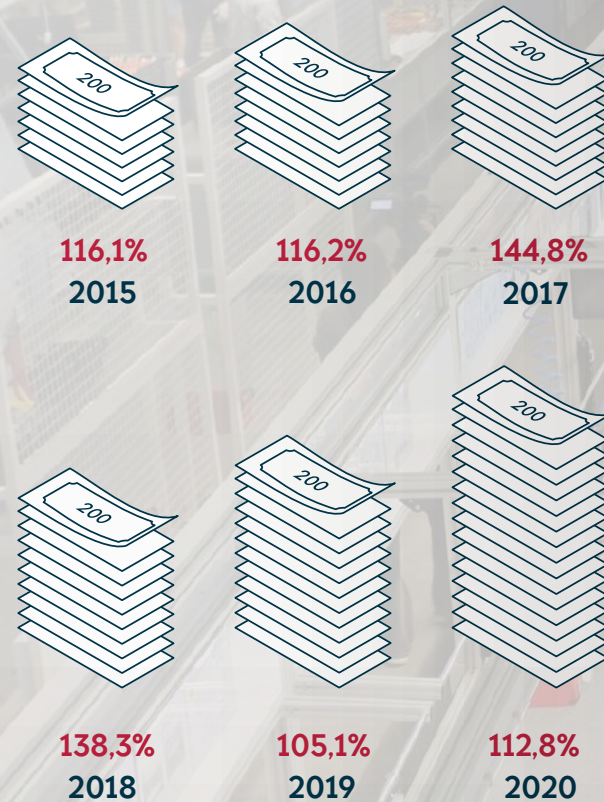

IN 2020, MOST VACANCIES IN KHMELNYTSKYI WERE OFFERED FOR

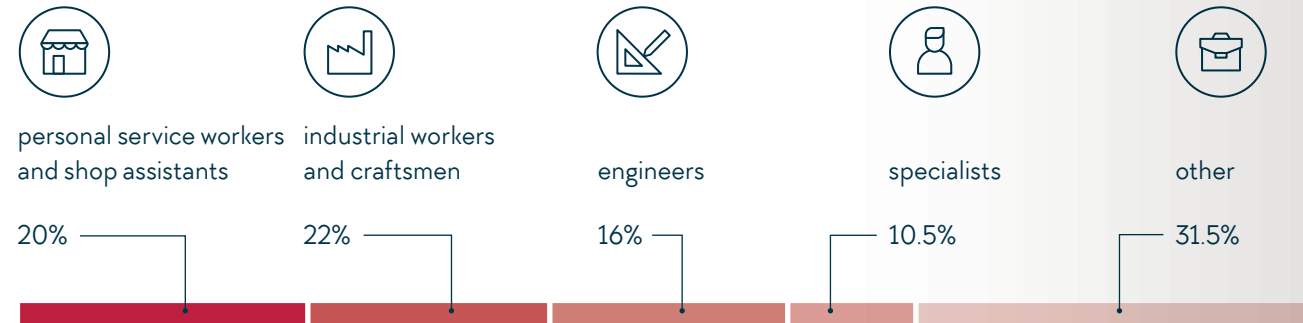

MAJORITY OF NEW JOBS IN THE PERIOD MENTIONED ABOVE WERE OFFERED BY



THE MOST WANTED SPECIALISTS SEARCHED BY EMPLOYERS ARE

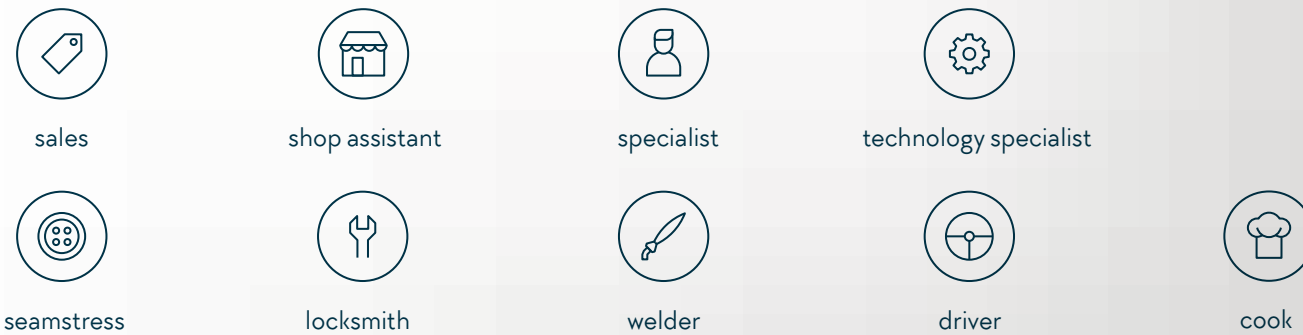

! A large proportion of the working population of the City has experience as technical professionals, skilled and unskilled labor in the European Union, especially Poland, Germany, Czech Republic and Lithuania, specialized in transport engineering, manufacturing equipment, electrical machinery, metal processing and so on."

FOREIGN ECONOMIC ACTIVITY

City enterprises are actively engaged in foreign economic activity.

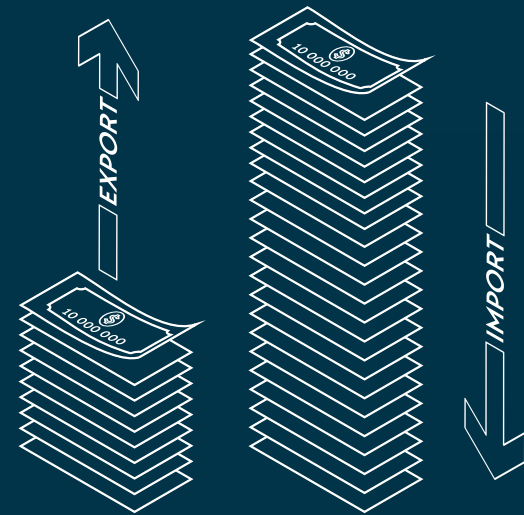

\$ 131,9 million

\$ 309.7 million

In 2020, export of good amounted to \$ 131,9 million while imports came to \$ 309.7

THE DISTRIBUTION OF EXPORTS

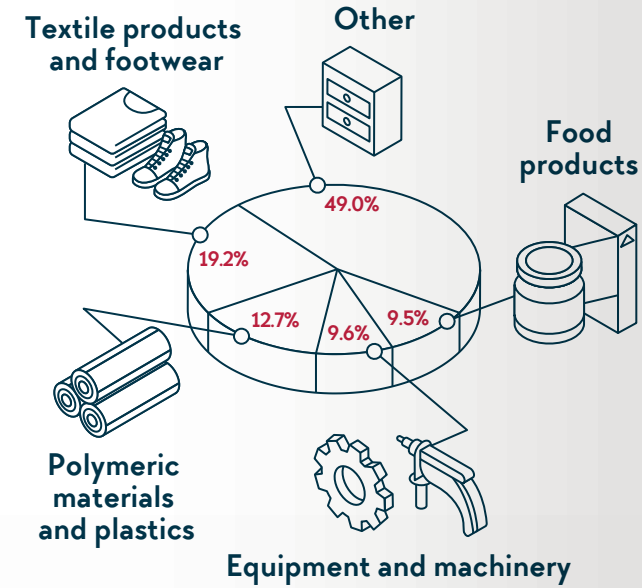

THE DISTRIBUTION OF IMPORTS

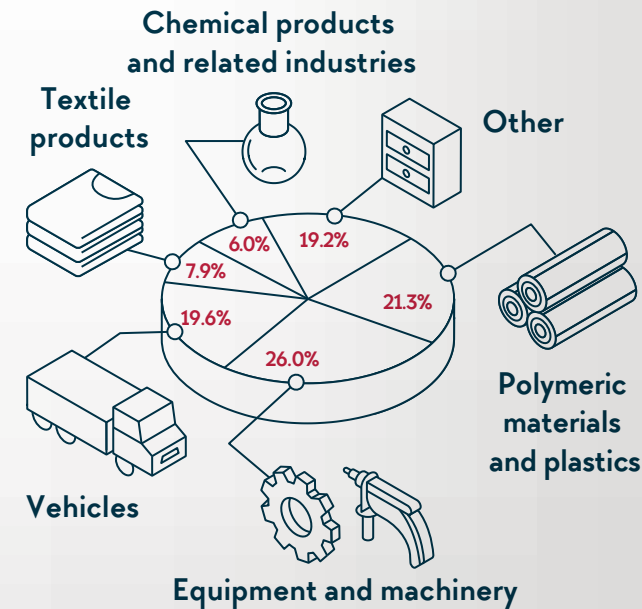

Each year the orientation of local enterprises to the markets of European countries increases in particular, in 2020 the share of the exports to the EU countries in total exports was 49.2 %

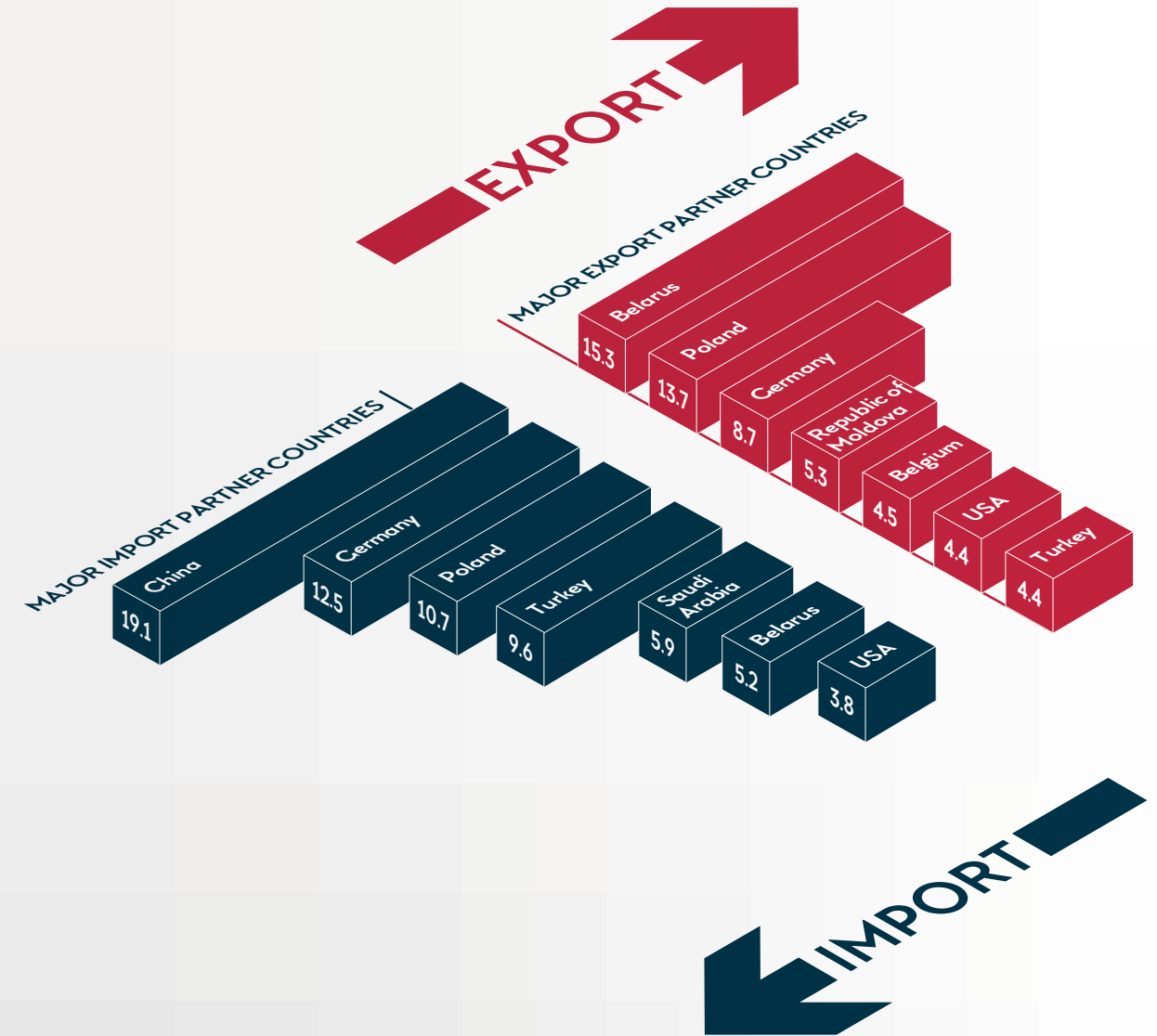

Import from EU countries amounted to 53.3 %

EDUCATION

Another advantage of *Khmelnytskyi* is its human capital. Schools of higher education of the city provide with study programs on management of hotel and restaurant business, marketing, entrepreneurship, trade and stock exchange activity, management of services, tourism and trade. All the institutions are open for cooperation with business entities, e.g. in the field of improving students' practical knowledge. It gives students the opportunity to be prepared to work for a modern company.

Vocational and higher education is represented by a branched system of educational institutions that trains specialists for different professions (13 high and 7 vocational schools). For business, there are wide opportunities for developing joint educational programs with vocational and technical schools for targeted training.

UNIVERSITIES

Because of the high level of quality of life in the city and wide educational opportunities, students gladly choose *Khmelnytskyi*. Despite the decline in the total number of students in Ukraine, the number of students in *Khmelnytskyi* has remained the same. Diverse fields of study including technology, engineering, economics, social sciences and many others attract young people to *Khmelnytskyi*.

The city universities are interested in improving the quality of educational services, attracting foreign students and offering wide range of training courses to provide labour market with a capable workforce.

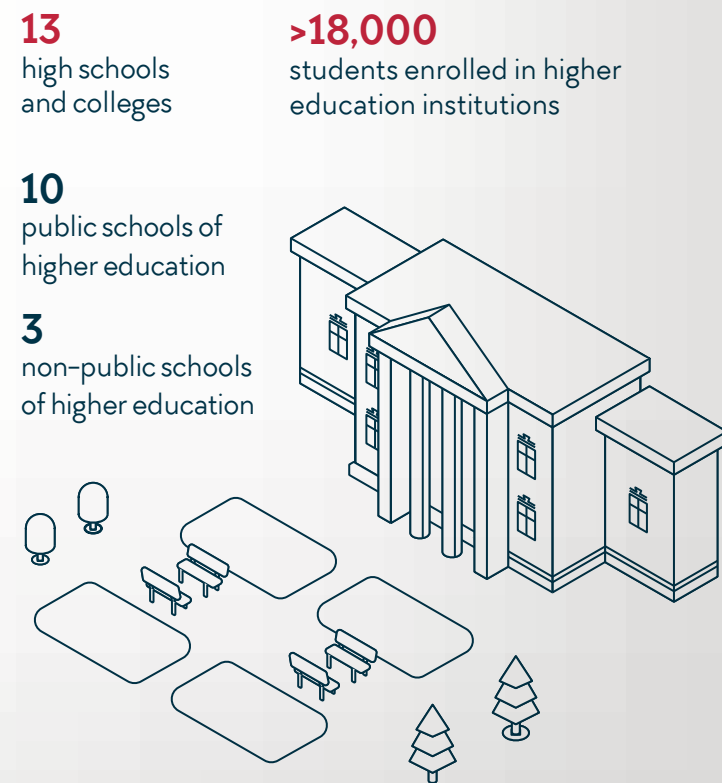

INDUSTRIAL PARK KHMELNYTSKYI

 **LOCATION:**
18, Vinnytske shose,
Khmelnyskyi city, Ukraine

 **THE TOTAL AREA:**
91 hectares.

 **TARGET USING:**
Under the industrial park.

 **CATEGORY OF LAND:**
The land of industry, transport, communications, energy,
defense and other purposes.

 **THE PLOT'S CHARACTERISTICS:**
A flat surface, free from buildings.

INDUSTRIAL PARK LOCATION

EUROPEAN ROUTES

- | | | |
|------------|---------------|-----------------|
| E40 | E50 | E85 |
| Dunkirk | Brest | Klaipėda |
| Brussel | Paris | Kaunas |
| Dresden | Nuremberg | Vilnius |
| Legnica | Prague | Lida |
| Krakov | Uzhgorod | Slonim |
| Lviv | Ternopil | Kobrin |
| Kyiv | Khmelnytskyi | Dubno |
| Kharkiv | Kropyvnytskyi | Ternopil |
| Volgograd | Dnipro | Chernivtsi |
| | Donetsk | Siret |
| | Rostov-on-Don | Suceava |
| | Makhachkala | Bucharest |
| | | Kastanies |
| | | Alexandroupolis |

UKRAINE ROUTES

- | | |
|------------|------------|
| H02 | H03 |
| Lviv | Zhytomyr |
| Ternopil | Chernivtsi |

VIA CARPATHIA

Planned transnational highway network connecting Lithuania, Poland, Slovakia, Hungary, Romania, Bulgaria, Greece, Turkey and Ukraine

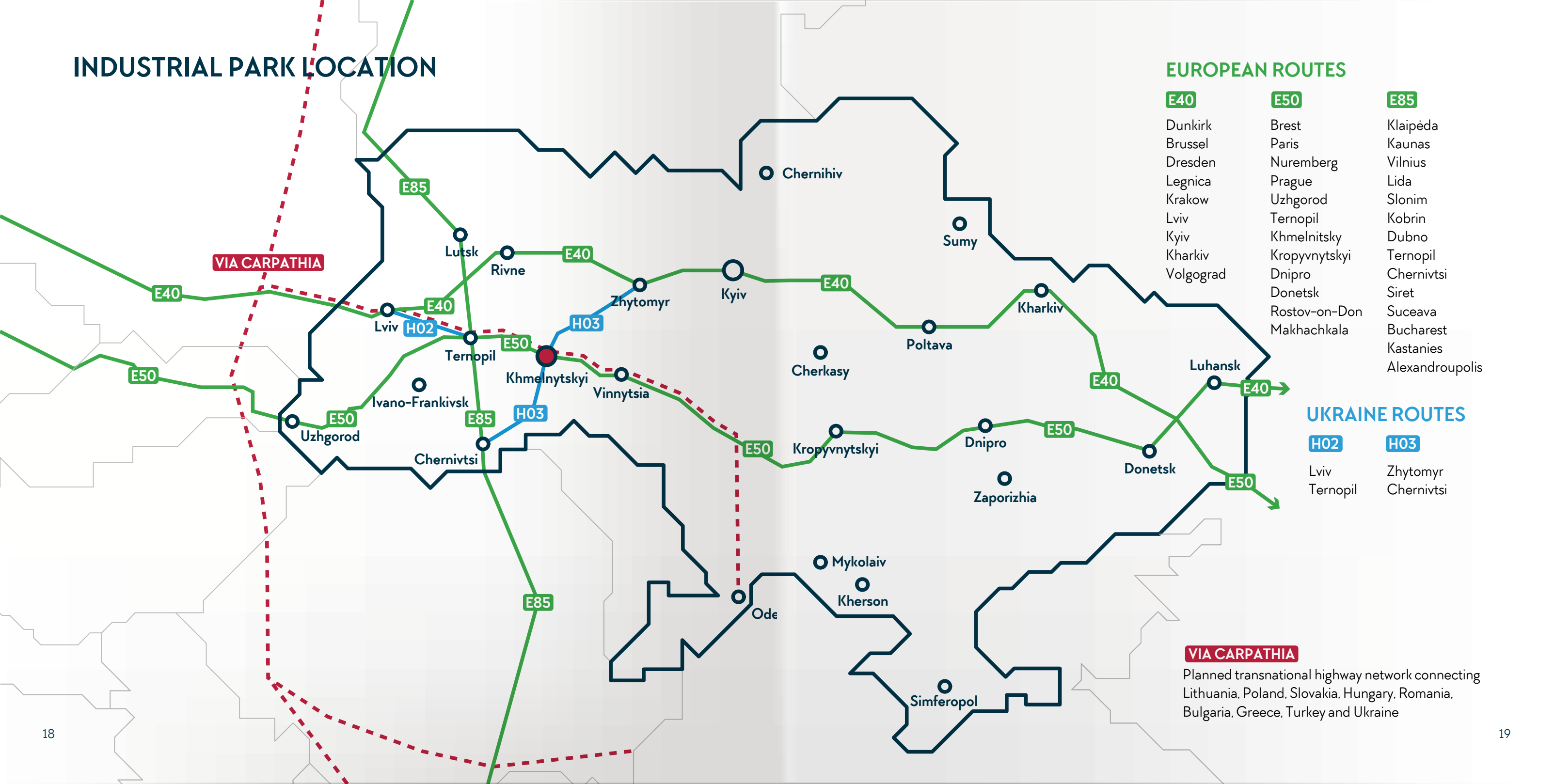



E50

H03

Airport

Retail Market

Nova Poshta
Logistic Terminal

H03

E50

Industrial Park

E50

INDUSTRIAL PARK PLANNING DOCUMENTS

A number of planning documents for the Khmelnytskyi Industrial Park have been prepared and are available for public review. These include:



Khmelnytskyi Industrial Park Creation and Functioning Program



Documents on the allocation of land and ownership of the land



Soil and water test reports



Technical report on detailed survey of the soil of the land plot

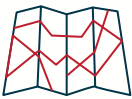

Detailed plan of the territory for the Industrial Park

The site is level.
Elevations vary from
275.3 to 276.79 m above sea level.

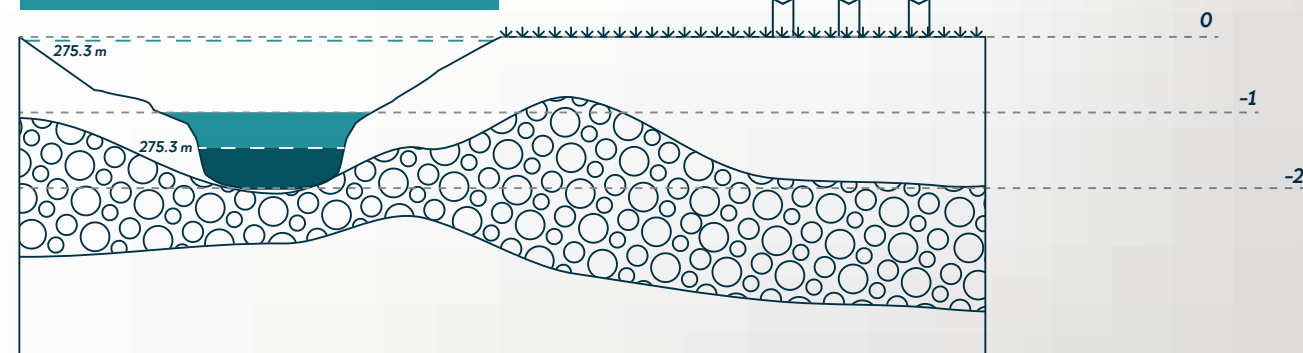
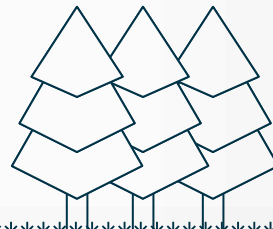

ADVANTAGES FOR PARTICIPANTS OF INDUSTRIAL PARK (NATIONAL LEVEL)

ESTABLISHMENT OF AN INDUSTRIAL PARK HAS A LOT OF ADVANTAGES

tax incentives

- duty exemptions for equipment used during industrial park arrangement
- duty exemptions for equipment used for business activities within the industrial park¹

government support

- interest-free loans
- irrevocable target financing for industrial park arrangement²

incentives in construction on the industrial park territory

- exemption from local development fees³

¹ Part 6 of Article 287 of the Customs Code of Ukraine

² Clause 9 of Article 27 of the Law of Ukraine "On Industrial Parks"

³ Article 36 of the Law of Ukraine "On Industrial Parks"

PRIVILEGES TO BE ADOPTED IN THE NEAR FUTURE

IN THE DRAFT LAW OF UKRAINE "ON AMENDMENTS TO THE TAX CODE":

 changes in taxes for park participants on profit from business activity

 added value

 real estate

 land tax

 rent for the use of the land plot.

IN THE DRAFT LAW OF UKRAINE "ON AMENDMENTS TO THE LAW OF UKRAINE "ON THE INDUSTRIAL PARK"









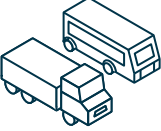

- 1) compensation of the costs for connection to electric networks
- 2) compensation of interest payment on loans
- 3) partial compensation of the investments (capital expenditures)

IN THE DRAFT LAW OF UKRAINE "ON AMENDMENTS TO THE CUSTOMS CODE":





 taxation of duties

 privileges on payment of import duty.

ADVANTAGES FOR PARTICIPANTS OF INDUSTRIAL PARK PROVIDED BY THE CITY LEVEL

-  Convenient location with respect to the city infrastructure (public transport, the possibility of unimpeded arrival of heavy and large-sized transport.)
-  Road-transport infrastructure
-  Integrated engineering network
-  Plots that are ready for sublease
-  Land, prepared for connection to infrastructure
-  Cancellation of a share contribution to infrastructure development
-  Privileges for local taxes
-  Preferences from the city, in particular rent rate of 0.01% for the calculation of land rent
-  The effect of synergy from the close placement of related industries
-  Ability to involve subcontractors of the region (mechanical engineering, metal working)

ADVANTAGES FOR PARTICIPANTS OF INDUSTRIAL PARK PROVIDED BY THE MANAGING COMPANY

-  Possibility of training workers in local vocational schools
-  The land in the industrial park is fully prepared for design /construction
-  Individual approach when choosing the area and location of the land
-  Topographic survey
-  Geological tests
-  Design, construction services
-  Legal support, registration of sublease agreements
-  Centralized connection to engineering networks
-  Corporate style and PR
-  Security
-  Comprehensive household and logistic services
-  On-site transport

THE SCHEME OF THE INDUSTRIAL PARK

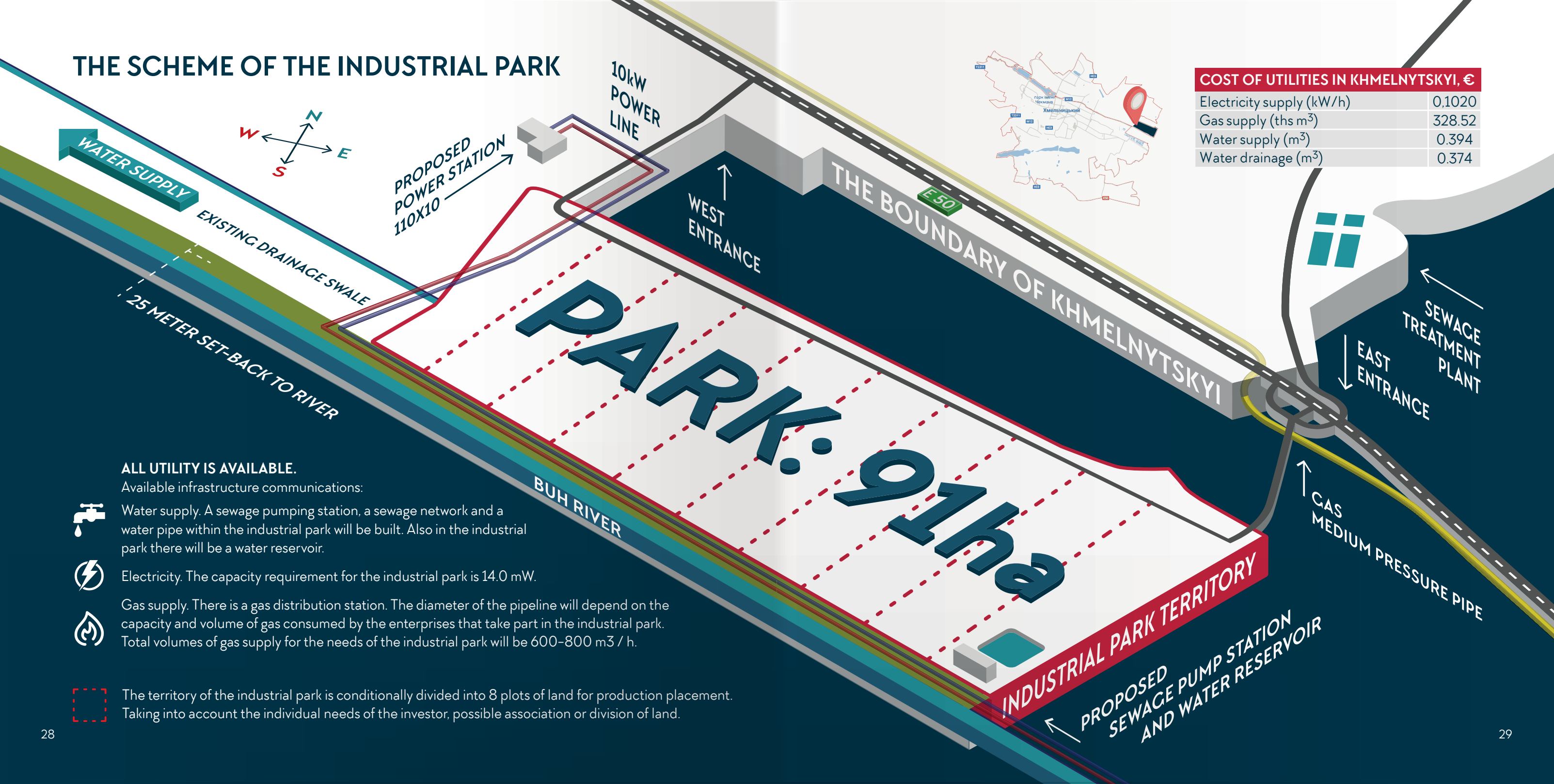

COST OF UTILITIES IN KHMELNYTSKYI, €

Electricity supply (kW/h)	0,1020
Gas supply (ths m ³)	328.52
Water supply (m ³)	0.394
Water drainage (m ³)	0.374

ALL UTILITY IS AVAILABLE.

Available infrastructure communications:



Water supply. A sewage pumping station, a sewage network and a water pipe within the industrial park will be built. Also in the industrial park there will be a water reservoir.



Electricity. The capacity requirement for the industrial park is 14.0 mW.



Gas supply. There is a gas distribution station. The diameter of the pipeline will depend on the capacity and volume of gas consumed by the enterprises that take part in the industrial park. Total volumes of gas supply for the needs of the industrial park will be 600-800 m³ / h.



The territory of the industrial park is conditionally divided into 8 plots of land for production placement. Taking into account the individual needs of the investor, possible association or division of land.

INFRASTRUCTURE OF THE INDUSTRIAL PARK

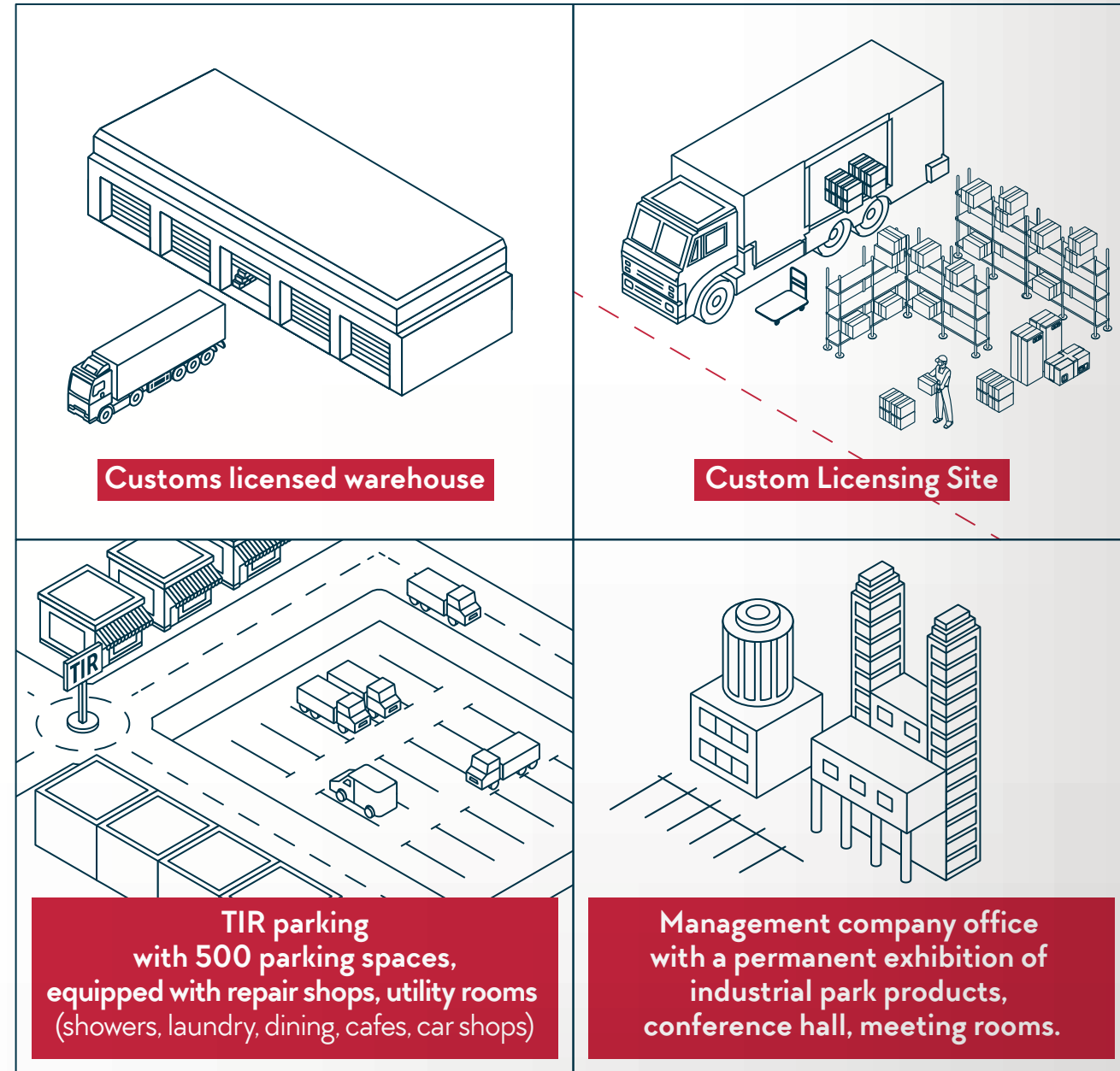

PRIORITY AREAS OF PRODUCTION

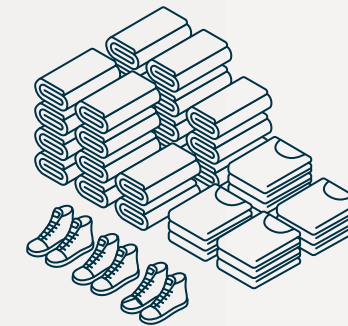

TEXTILE PRODUCTION

- weaving production
- clothing production
- production of other textile products

MACHINE INDUSTRY

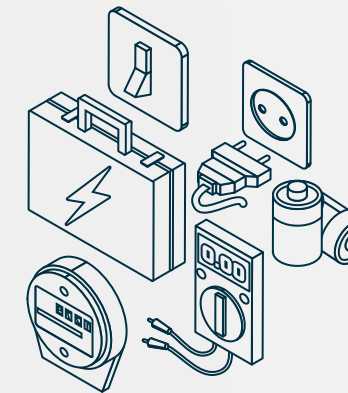

PRODUCTION OF ELECTRICAL EQUIPMENT

- production of electric motors, generators, transformers, power distribution and control equipment
- manufacture of batteries and accumulators
- production of wires, cables and wiring devices
- production of electric lighting equipment
- production of household appliances
- production of other electrical equipment



AGRO PROCESSING

- food production
- processing and preserving of fruits and vegetables
- production of the flour-grinding industry
- production of other food products

KHMELNYTSKYI INDUSTRIAL PARK ORGANIZATIONAL MODEL

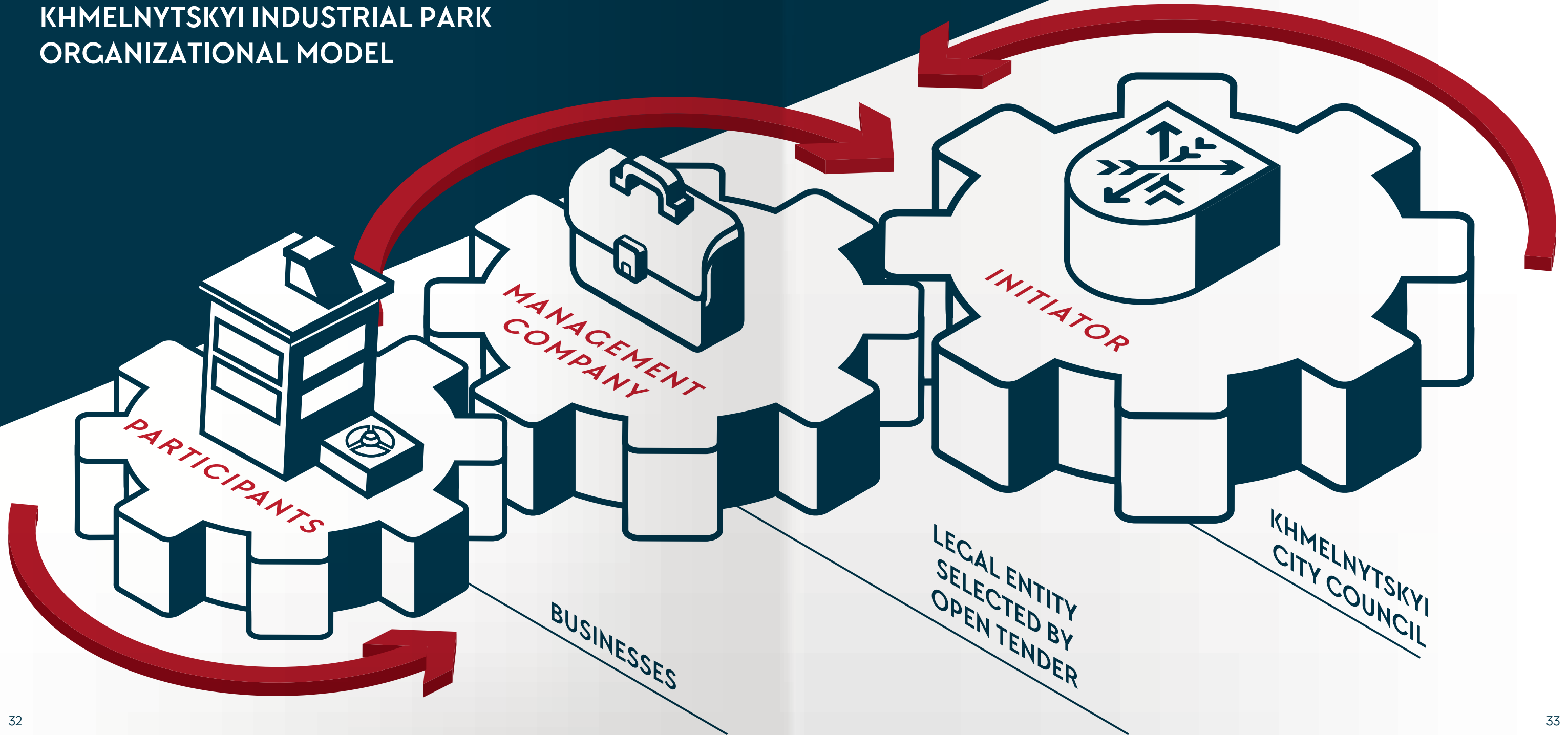

THE PERIOD FOR WHICH THE INDUSTRIAL PARK IS CREATED



YEARS

EXPECTED RESULTS

INVESTMENTS

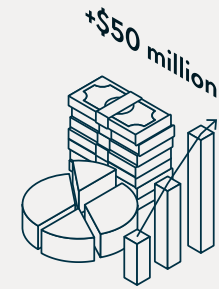

Planned to attract at least \$ 50 million direct investment in the city's economy. Expected import of equipment and components to them, materials that are not produced in Ukraine.

WORKING PLACES

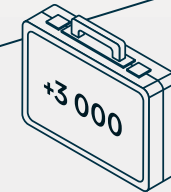

Planned to create more than 3000 new jobs.

NEW ENTERPRISES AND INNOVATIVE TECHNOLOGIES

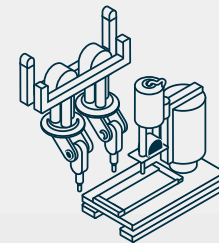

Planned to create new enterprises with high potential of innovative development, growth of added value and closed production chains.

FILLING THE BUDGET



Planned to increase the revenues of additional funds to the local budget by at least 10 percent.



Khmelnytskyi City Council



Head of Economic Department
Oksana Novodon
+38 (067) 311 11 09 novodon@ukr.net

www.khm.gov.ua

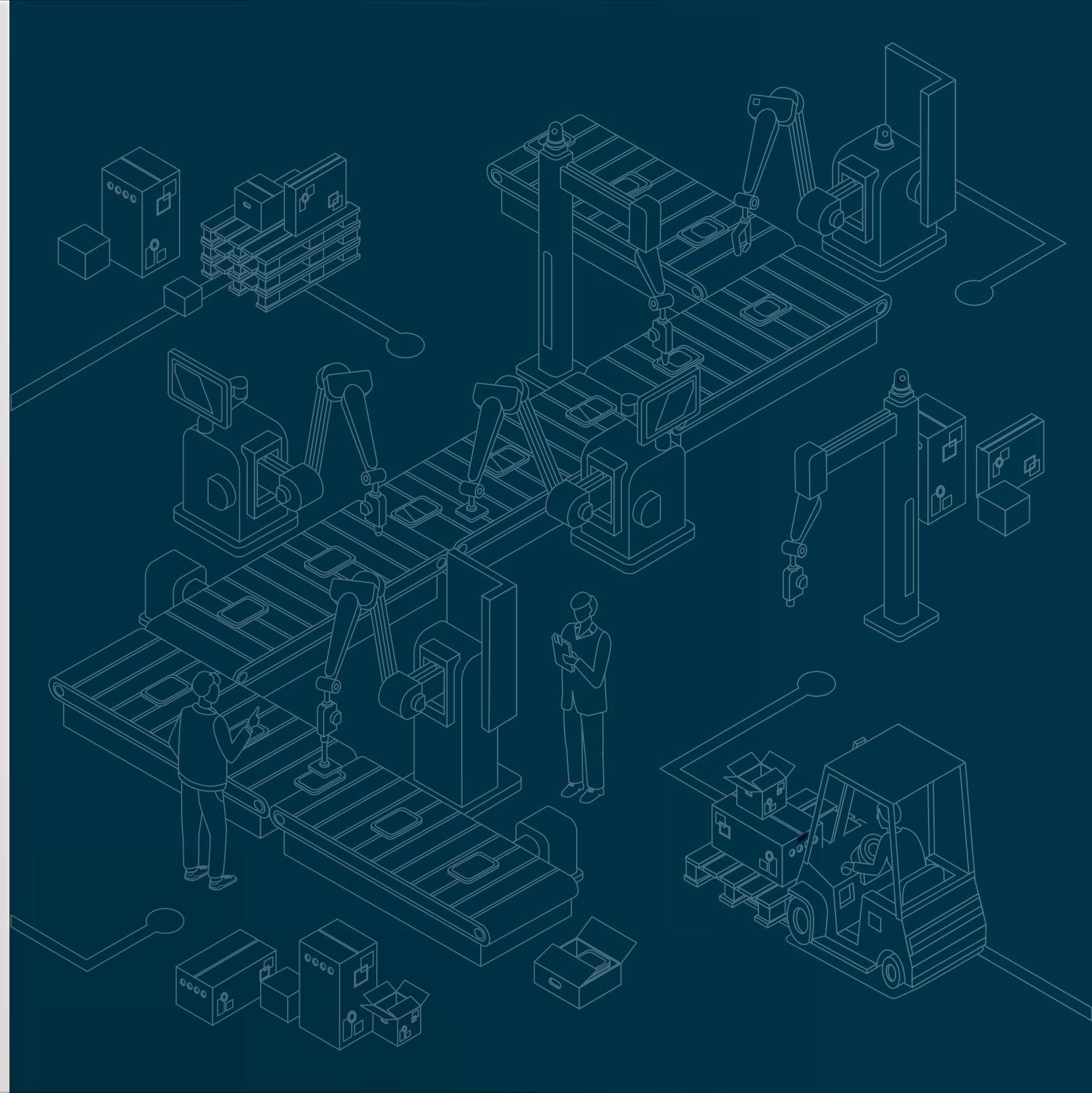

Invest in  the future.